

Demountable / Mobile flood protection systems

Recommendations on planning, selection, providing and using

CFPA-E Guideline No 7:2018 N





FOREWORD

The European fire protection associations (CFPA-E) have decided to produce common guidelines in order to achieve similar interpretation in European countries and to give examples of acceptable solutions, concepts and models. The Confederation of Fire Protection Associations in Europe (CFPA-E) has the aim to facilitate and support fire protection work in European countries.

The market imposes new demands for quality and safety. Today, fire protection forms an integral part of a modern strategy for survival and competitiveness.

The measures of Natural Hazards Guidelines concern not only operators, businesses, specialists and plant officers, but also the population and local administration. This is due to the fact that in contrast to fire, the impact of natural hazards as a result of drought, are often very widespread.

The proposals within this guideline have been produced by GDV, Gesamtverband der Deutschen Versicherungswirtschaft e.V., and Dr.-Ing Mingyi Wang has done the final preparation.

The Guideline has been compiled by Natural Hazards Group in the Guidelines Commission and adopted by all fire protection associations in the Confederation of Fire Protection Associations Europe.

These guidelines reflect best practice developed by the countries of CFPA Europe. Where the guidelines and national requirement conflict, national requirements must apply.

Copenhagen, February 2018
CFPA Europe

Jesper Ditlev
Chairman

Madrid, February 2018
Guidelines Commission

Miguel Vidueira
Chairman





Contents

1 Introduction 4

2 Scope 4

3 Definitions..... 4

4 Examples of available systems 5

5 Functional characteristics as criteria for selection of systems..... 11

6 Operational experiences 12

7 Quality assurance measures 12

 7.1 Verification of suitability and their assessment 12

 7.2 Declaration of the manufacturer..... 13

 7.3 Operating precautions for proper use 13

8 Literature 13

9 Appendix: Functional characteristics of sandbag systems (of jute or plastics)
- An example and a check list of the system assessment 14

10 European guidelines..... 17

Key words: flood, demountable / mobile protecting system, functional characteristics, criteria for selection, quality assurance



1 Introduction

The flood events of recent years have shown that significant damage can occur due to flooding. In addition, the existence of many companies can seriously be endangered because of a longer service interruption due to a flood.

According to loss experience losses caused by flooding can be significantly limited by preventive measures. In this context especially stationary protective measures have proved successful. Mobile protection systems can complement or replace stationary protection systems because of operational or areal constraints.

To establish appropriate protection measures the existing hazards must be identified and analyzed as well as the associated risks assessed. The relevant objectives, e.g. the height of protecting wall, are to be defined object-related and depending on the legal requirements and risk assessment.

Object-related protection measures should be coordinated with local protection concepts, because floods are usually large-scale events and object-related measures can only be effective if they are embedded in the local protection concepts. In addition, potential threats to the stability of buildings by buoyancy or penetrating groundwater are to be considered in the risks assessed.

2 Scope

The present guideline covers the planning, selection, providing and using of mobile flood protection systems. Mobile flood protection systems are currently widely available on the market. The aptitude test of these systems is, however, still according to different criteria and by various methods. For this reason, notes and typical criteria for selection of suitable mobile flood protection systems are systematically prepared as recommendations, in order to support the decision-makers, planners and managers of flood protection to take appropriate measures in practice.

This publication is based on the current knowledge and previous experience of loss prevention and risk management. It will be reviewed regularly and updated when there are significant improvements resulted in the specified fields.

Legal regulations are not affected.

3 Definitions

Stationary flood protection systems: structural protective measures that are largely ready without foreign action and so ensure their full protective effect permanently

Mobile flood protection systems can be divided simplified as follows:

- Scheduled systems that are transported and assembled in case of application to the site. The installation of these systems requires physical provision on-site.
- Standard emergency systems that are marketed and assembled without physical provision on-site.

Stationary systems with movable elements, which are activated in case of application can be assigned to mobile systems.

Note: Mobile flood protection systems can be used for both area protection and object protection. Their suitability must be tested and proved for the intended purpose, which may have very different application conditions.

4 Examples of available systems

Mobile flood protection systems can be designed and used both for the protection of areas as well as for the protection of individual objects, e. g. fitted in building openings (doors, gates, driveways). Following typical mobile flood protection systems are listed without any claim to completeness. They are briefly described with schematic illustration and by the following characteristics:

- basic structure
- area of application and
- Logistics and Maintenance.

With it the selection of locally appropriate protection system in practice should be supported.

- Floating barrier systems

Basic structure: Floating barrier systems consist of underground flood chambers which are connected to the waters above pipes or channels, and wall elements or sections that rest in the chamber. The individual elements of the flood protection wall are formed as a floating body. In case of flood they can either float vertically or lift themselves.

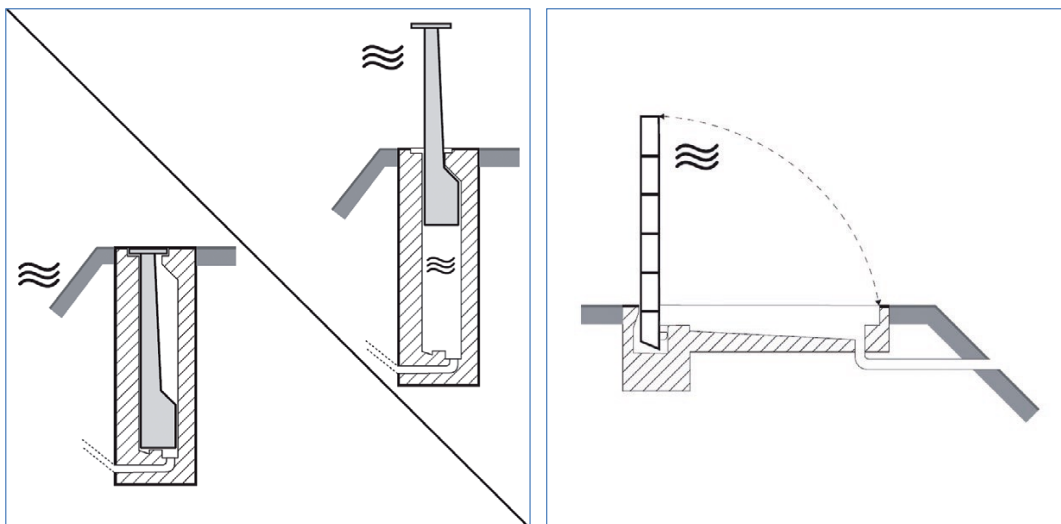

Figure 1 Examples of Floating barrier systems

Area of application: These systems can be used to protect passages - such as dikes, walls or between buildings. Individual elements can be longer than ten meters and combined into longer walls. With such systems a level of protection of several meters can be realized.

Logistics and Maintenance: Due to the stationary installation logistics is not required. The cost of maintenance is however quite high, among other things for the removal of sediments in the flood chamber, eliminating of icing, pumping of rain water, corrosion protection.

- Dam beams or board stop log systems

Basic structure: These systems consist on the one hand of wall elements, which are designed as stackable dam beams or dam boards. On the other hand, columns serve as a counter bearing for the horizontally stacked beams or the lined boards. To accommodate the horizontal forces the mobile columns are force-fit connected by means of foundation with the ground, e. g. with anchor plates, bolt or bolts.

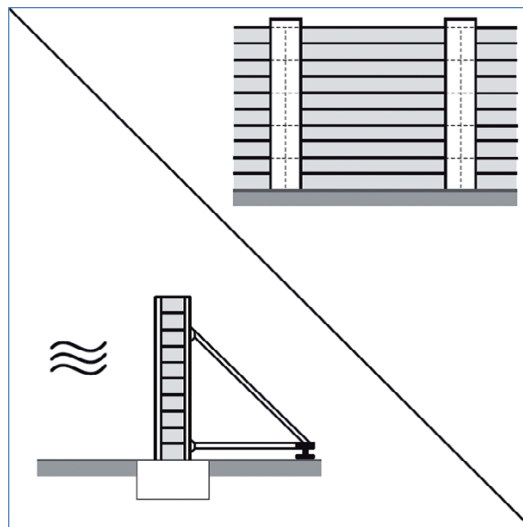

Figure 2 Dam beams or dam board stop log systems

Area of application: These systems are suitable both as area flood control systems in the field of open spaces as well as for use in the passage between buildings or other stationary flood control facilities. With such systems a level of protection of several meters can be realized. The distance between columns is usually several meters. With the increasing level of protection additional supports may be required.

Logistics and Maintenance: Before and after the use adequate storage capacity for the columns and stop log elements and seals are required. In case of use it must be ensured that the right elements are used in the right place by orderly logistics for removal from storage, transport and installation on site (integration in an alarm plan).

- Folding systems (possibly with impact protection)

Basic structure: These systems consist of individual plate-shaped segments merged by rigid foot parts or connected by plastic tarps. They are swing opened in case of use at the site or lift themselves with the incoming water. A tear resistant and watertight blanket at the edges of the segments forms a flexible joint and seals the joints between the neighbouring segments. They may need to be fixed in the ground by earth screws or anchors. In permeable substrates pre-installed concrete aprons with connection profiles and plastic sheeting that incorporated into the soil may be necessary to prevent undercurrent through the soil.

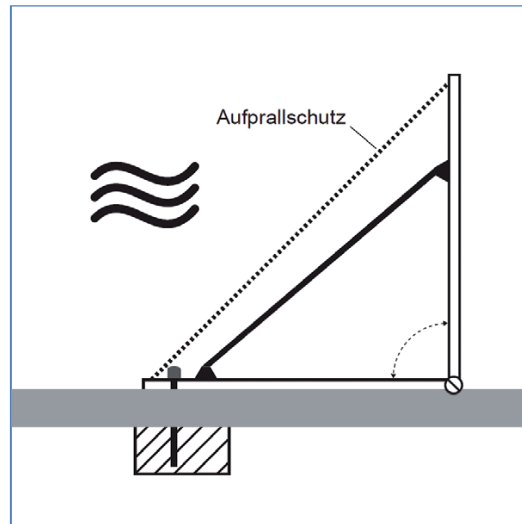

Figure 3 Example of folding systems

Area of application: Folding systems require substantially flat mounting surfaces; terrain slopes are tolerable to some degree. Individual barrier elements can be joined together to longer wall sections or individual passages between buildings or stationary facilities can be sealed.

Logistics and Maintenance: Regarding to the logistics and maintenance preinstalled folding systems are comparable with floating barrier systems and systems with partly or completely mobile components with dam beams or board stop log systems.

– Sandbag systems

Basic structure: Sand bags are made of jute or plastic and can either be filled with sand or grit. When using, note that the bags are filled only to $\frac{2}{3}$ and the filling opening are placed opposite the water side. Filled sandbags can have a weight of about 12 to 20 kg. To improve the seal on the water side plastic sheets also be placed.

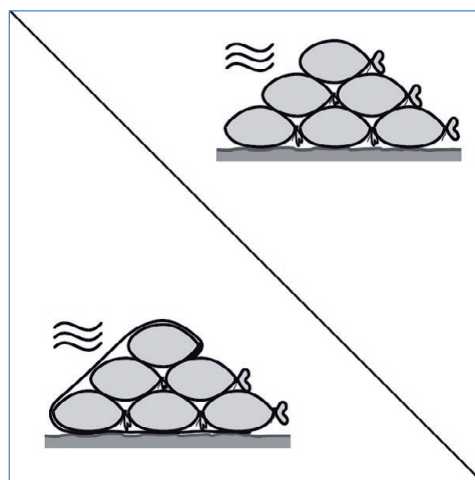

Figure 4 Example of sandbag systems



Area of application: Sandbags can be stacked mound-like without further assistance by hand. Their applications are many, e. g. door or window openings, light wells, driveways but also entire streets can be protected through dams of any length. In addition, sandbags are used to secure dike, to increase the protecting level of existing levees or walls, or in combination with other protection systems, such as the bock systems.

Logistics and Maintenance: Shall sandbag systems extensively used for, e. g. as the construction of dams, a large number of workers for filling and subsequent distribution to the dam construction is necessary. For faster filling of sandbags filling-aid, e. g. sandbag hopper and other filling machines have proven.

After a flood event it must be decided on the basis of pollution levels, what happens to the sandbags? If they are contaminated with oil or chemicals, for example, they must be professionally cleaned or disposed of. Otherwise pre-filled sandbags should be stored dry and protected from the weather.

- Container systems (filled with water or sand)

Basic structure: Open container systems strung together form a protective barrier. They can be filled with water or sand. The outer sheath for systems filled with sand can consist of tear resistant geotextile fabric and for systems filled with water from reinforced PVC. In addition, there are also systems made of fiberglass reinforced plastic panels with plastic sheet that be rolled into cylinders and closed with a simple system.

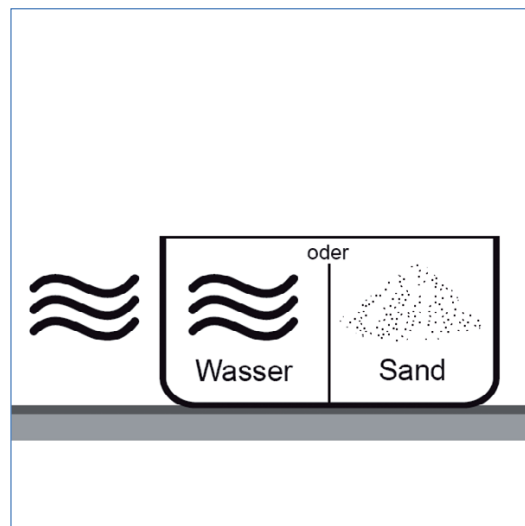

Figure 5 Example of container systems

Area of application: With container systems dams of any length can be constructed. In general the tightness in the coupling areas between containers is already given by the pressure of the filled containers or they may need connected each other in the site, e. g. by screw. If it fits on the dimension gateways or wall openings can be locally sealed with the container systems. With container systems a protection level of about 0.5 to 2 m can usually be achieved. Container systems can possibly be used in rough terrain, since no heavy tools are required for their construction and transport.



Logistics and Maintenance: Depending on the type of system, e. g. with or without frame, the required space for storage is very different. Also depending on the type container systems and their parts can be reused. When reusing the system, its elements must be emptied, cleaned, if necessary, and dried.

– Bock systems

Basic structure: These systems are essentially composed of three components: Support construction, wall elements (e.g. Euro pallets or metal plates.) and plastic seal sheet. To fix the support structure on the ground nails or anchor bolts are used. On support structure, the wall elements are assembled and fixed to the ground with sandbags; the seal sheets are placed on the water side of the wall elements.

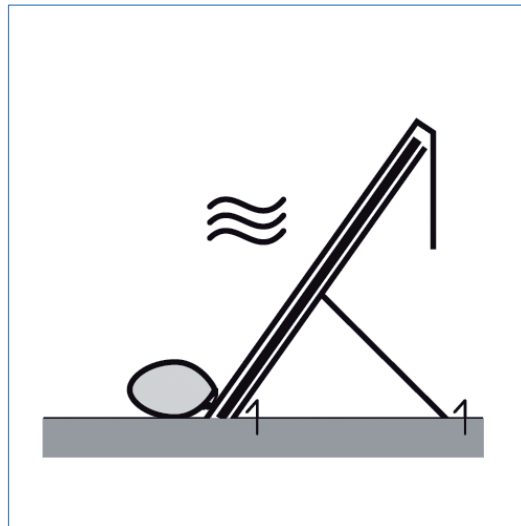

Figure 6 Example of Bock systems

Area of application: Bock systems can be used for protection of area or objects. With Bock systems dams of any length and, depending on the type of system, protection level of up to 1.5 m can be achieved. Systems with Euro pallets are quite inflexible in length due to the unit width of each pallet. To ensure the stability of Bock systems, the ground must be stable and relatively flat; using on soft ground is not recommended.

Logistics and Maintenance: To ensure a rapid installation of bock systems, a systematic logistics with orderly storage is necessary. After using bock systems must be controlled, cleaned, dried and can be reused subsequently.

– Hose systems (filled with water, sand or air)

Basic structure: Hose systems based on the same principle: tubular or trapezoidal plastic container are filled with water, sand or air. They get their stability through ground plane on the water side. By water-filled systems with a circular cross section two hoses shall be laid side by side in parallel and interconnected, so they do not roll away by the water pressure of the floods. Their use is however problematically in frost. Freeze the water body in the tubing problems of stability can be caused.

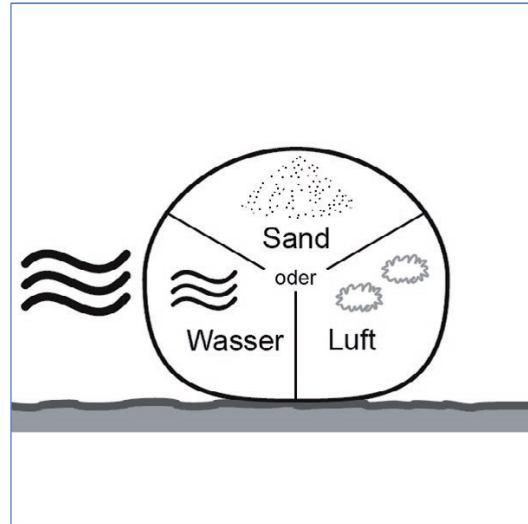

Figure 7 Hose systems

Area of application: Hose systems can very well fit to the topography due to their flexibility and can be used at different ground conditions. With hose elements coupled to each other with cuffs, dams of any length for protection of area and protection level of up to 1.5 m can be achieved. Furthermore, the protection level of existing dikes, provided sufficient stability, can be increased by hose systems. The flexible outer shell of the hose also allows the local sealing of passage for driveways or wall openings.

Logistics and Maintenance: After using the hoses must be emptied and dried and examined for cracks and abrasions and repaired if necessary. Subsequently hose systems can be reused.

– Other systems

As other systems, among other things, even provisional systems, for example board or precast concrete systems, may be called. These systems can be quickly provided with materials that are available on sites, e.g. on construction site and building materials storage areas. Provisional systems are due to the lack of systematic dimensioning not recommended and therefore not described here.

– Mobile backflow protection

Basic structure: These systems are on the one hand inflatable sealing elements that are introduced and inflated into existing sewer openings, and on the other hand prefabricated, adjusted sheets or plates in customized degree.

Inflatable sealing elements are available as:

- shut-off disks
- shut-off bubbles
- sealing bags
- shaft sealing bags and
- inflatable plug for pipelines.



The elements are a combination of rubber bubbles with metallic lines or valves for inflation. They are available in different sizes. It is recommended to pre-determine the required sizes and quantity of the needed systems and to procure and provide these.

For shafts there are prefabricated panels with screw and fasteners. These are available for purchase in certain sizes or are individually made, usually of metal

Area of application: Mobile backflow protection systems are used to seal manhole covers, processes, pipes and opening of shafts.

Logistics and Maintenance: All mobile backflow protection systems are prefabricated elements and provide planned. Only the plug for sealing pipes is to be foreseen as an emergency measure. When creating protection concept stationary backflow protection systems are to be preferred. This is definitely required when wastewater must be discharged during the flood.

5 Functional characteristics as criteria for selection of systems

Apart from the costs for acquisition and operation mobile flood protection systems differ among others, with respect to the structure, permissible application areas and the need and expense for the logistics and maintenance. Simplified, these functional characteristics as evaluation criteria are divided into the following topics

- Type of System
- Scope of application: Applications or system limitations according to the testing and approval, e. g. maximum water level
- Material: Susceptibility to frost, resistance to salt water and UV
- Statics: Integrity and load capacity, stability (resistance against flotsam or mechanical effects, susceptibility to vandalism, ...)
- Tightness; Test methods and allowable leakage, compensate for uneven surfaces and soil bearing capacity, ...
- Costs (Reference base L x H = 100 m x 1 m): life, reuse or disposal, necessary structural conditions and additional costs for these
- Operation expense (Reference base L x H = 100 m x 1 m): time, devices, people and manual and training for installation
- Expenses for maintenance after use: needed time, devices and number of people
- Expense for periodic maintenance: Time, devices, number of people and other, e. g. additional measures to protect against feeding animals
- Logistics: weight of typical individual elements, maximum dimensions of the standard system, necessary capacity required for storage (e. g. per 100 m), storage outdoor or protected indoor, necessary transport capacity
- References (e. g. practical assignments and also in the sense of the product liability protection.

In the appendix of this publication, the user finds a basis for comparison review of sandbags. The choice of the example falls on sandbags, because they already tested for many years in the mobile flood protection and are also independent of the manufacturer.



6 Operational experiences

The preparation and explanation of the functional characteristics as criteria for selection have clearly shown that the use of mobile flood protection systems should be practiced regularly, because the participating institutions and operation personnel must be attuned to each other, despite an in-depth planning. This also applies to the head of operations including ensuring the communication in case of failure of mobile networks and to the logistics. The timely and proper set up of the mobile protection systems therefore presupposes ahead, inter alia, the following

- The application site, e. g. the access road, is shut off over a wider area as possible and clearly visible properly signposted. According to experience a shutting off single lanes has shown insufficient
- Entrances to the operation site are guarded during the duration of operation, e. g. by trained security personnel that can authenticate by
- The traffic should be redirected via large-scale route diversion and redirection is clearly visible to mark and to announce the press
- The required capacity of logistics should be constantly provided, if necessary via binding contracts
- The required material and the corresponding storage are each to mark clearly and legibly
- Drive and walkways in the storage are also to mark clearly and visibly
- Tool with the required functional characteristics, such as ladder and rolling scaffolding up to a working height of 3.5 m, and substitute material such as screws are to provide in a sufficient number
- The operation personnel must be introduced uniformly and thoroughly; especially the Interaction between logistics and the set up should be practiced sufficiently
- The operation personnel are to inform about the current water levels that should be also visualized in the exercise.
- The operation personnel should carry necessary protective equipment, such as helmets, safety vests. They are sufficiently to provide.
- The supply of the teams on site is to ensure duration the entire operation. The ways of supply should be as short as possible.

According to experience it is useful for the implementation of practice to define a realistic scenario and to inform residents in time, e. g. with the help of the press and information signs and banners at the site and its entrances.

7 Quality assurance measures

The protective functions of mobile flood protection systems in case of use will be determined significantly by the properties of the systems on the one hand and on correct assembly on the other hand.

7.1 Verification of suitability and their assessment

The required characteristics of mobile flood protection systems, such as the stability and tightness depending on the water pressure and resistance to mechanical impacts, must– like with all other security related products – always be proved by the tests of prototypes related to approved methods and procedures.



7.2 Declaration of the manufacturer

Mobile flood protection systems can have different properties with respect to the area and object protection. To support the choice of appropriate protection systems for local conditions in practice manufacturers should provide the all functional characteristics as information for the user.

7.3 Operating precautions for proper use

For the use of mobile flood protection systems sustainable maintenance of the components and a solid operational and logistics planning are always required.

The emergency response plan must contain reporting chains, required warning and mobilization times and define of necessary personnel, e. g. for set up, and transportation capacity.

As far as interfaces consist of flood protection measures in the public sector, it must be ensured that effects of changes in public area are recognized and taken into account to the object-related protection system. This can be, for example, hydraulic engineering measures on waters (including dams, bridges, and retention areas), changes in the neighborhood in terms of surface drainage and development or changes to flood control measures in public ownership.

8 Literature

Gesamtverband der Deutschen Versicherungswirtschaft e. V. / Hochwasser-Kompetenz-Centrum
"Mobile Hochwasserschutzsysteme; Hinweise für die Beschaffung, den Einsatz und die
Bereitstellung " (VdS 6001) http://vds.de/fileadmin/vds_publicationen/vds_6001_web.pdf



9 Appendix: Functional characteristics of sandbag systems (of jute or plastics) - An example and a check list of the system assessment

Systems Characteristics	Sandsack (jute)	Sandsack (plastic)
Company		
Area of application		
(a) Area or property protection	Area and property protection	Area and property protection
(b) Capabilities and system limit	In dikes, a maximum height of about 2 m can be reached	In dikes, a maximum height of about 2 m can be reached
Material		
(a) Basic material	Jute, filling material: sand, Split	Plastic, filling material: sand, Split
(b) Susceptibility to frost		
(c) Salt water / UV resistance		UV stabilized or UV-resistant
Permissible water level		
Static		
(a) Stability and bearing capacity (Domino effect)	When applying the correct stacking technique in dike construction may have rather high stability. Jute bags interlock well even when wet.	Lower stability than jute bags as increased hazard of slipping.
(b) Stability (eg resistance to flotsam and mechanical effects)		
(c) Vulnerability to vandalism	Sandbags can be removed from the dam.	Sandbags can be removed from the dam.
Tightness		
(a) Test methods and allowable leakage?	As a result of swelling of jute bags in contact with water tightness is increased, but not 100% tightness.	Not 100% tightness.
(b) Compensation of uneven ground and soil bearing capacity	Sandbags nestled on uneven ground.	Sandbags nestled on uneven ground.



Costs		
a) Cost (Procurement) per opening or L x H = 100 mx 1 m	Jute bags without filler: 5.600 € (14,000 jute bags (sales promotion, 2004) à € 0.40) Costs filler: € 3,150 (15 kg of sand per sack, 1 t of sand à 15 €) Cost-filled burlap sacks: € 8750	Plastic bags without filler 2,800 euros (about 14,000 plastic bags (sales promotion, 2004) à € 0.20) Costs filler: € 3,150 (15 kg of sand per sack, 1 t of sand à 15 €) Cost filled plastic bags: € 5,950
(b) Life time	Usually, only mission	Several missions possible.
(c) Reuseability or disposal	Generally not reusable because wet jute bags rot quickly. When contamination by contact with oil, etc., proper disposal is necessary. Otherwise Jute is a natural material and can easily be disposed of. werden.	In general, reusable.
(d) Necessary structural requirements (Addition costs)	No	No
Effort for installation per opening or for length x height = 100 mx 1 m		
(a) Time	3 hours	3 hours
(b) Equipments	48 truck for transport, about 8 forklift truck for loading and unloading.	48 truck for transport, about 8 forklift truck for loading and unloading.
(c) Persons	50	50
(d) Guidance / training for installation	"Please note: - Fill sandbags only 2/3 so they nestle when laying on rough - Filling opening opposite the water side - - Observe the stacking technique depending on the application - Use of foil can also protect against the leakage of water	"Please note: - Fill sandbags only 2/3 so they nestle when laying on rough - Filling opening opposite the water side - - Observe the stacking technique depending on the application - Use of foil can also protect against the leakage of water
Efforts for maintenance after use		
(a) Time	"No maintenance required, since usually only used for one mission. If the sack is to be reused, the sand must be removed and the bag is completely dry. "	Bags must be dried after use
(b) Equipments		
(c) Number of person		



Regular maintenance		
(a) Time		
(b) Equipments		
(c) Number of persons		
(d) Other, e. g. additional measures to protect against feeding animals	Jute sandbags can be pre-filled poorly stored, since the moisture of the sand alone can lead to a decay process after a short time. Are the bags once wet, they must be dried. Therefore, regular maintenance is filled and stored bags is necessary.	Plastic bags prefilled can be quite easily stored at proper storage over long periods
Logistic		
(a) Net weight of typical individual elements	Filled sandbag, dry: 15 kg Filled sandbag, wet: 20 kg	Filled sandbag, dry: 15 kg Filled sandbag, wet: 20 kg
(b) Storage place: Outdoors or protected against weather	Protected against weather and light, store away from direct sunlight and dry.	Protected against weather and light, store away from direct sunlight and dry.
(c) Max. Dimensions of standard system	Sandbag empty: 35 x 70 cm Sandbag filled: 25 x 50 x 8 cm	Sandbag empty: 35 x 70 cm Sandbag filled: 25 x 50 x 8 cm
(d) Space for storage per opening protection or L x H = 100 mx 1 m	One euro pallet (1.20 mx 0.80 m): 50-70-filled sacs For dike L x H = 100 m x 1 m: 200-280 euro pallets needed, corresponding to an area of 192-269 square meters.	One euro pallet (1.20 mx 0.80 m): 50-70-filled sacs For dike L x H = 100 m x 1 m: 200-280 euro pallets needed, corresponding to an area of 192-269 square meters.
(d) Transport capacity	One truck respectively 5-ton carry capacity: 300 filled sandbags	One truck respectively 5-ton carry capacity: 300 filled sandbags
Certification		
Practical application	Elbe flood, August 2002 Flood Krems, August 2002Flood Dresden, April 2006Oder flood, May 2010	Elbe flood, August 2002 Flood Krems, August 2002Flood Dresden, April 2006Oder flood, May 2010

Origin source: VdS 6001



10 European guidelines

Fire

- Guideline No. 1:2015 F - Fire protection management system
- Guideline No. 2:2013 F - Panic & emergency exit devices
- Guideline No. 3:2011 F - Certification of thermographers
- Guideline No. 4:2010 F - Introduction to qualitative fire risk assessment
- Guideline No. 5:2016 F - Guidance signs, emergency lighting and general lighting
- Guideline No. 6:2011 F - Fire safety in care homes for the elderly
- Guideline No. 7:2011 F - Safety distance between waste containers and buildings
- Guideline No. 8:2004 F - Preventing arson – information to young people
- Guideline No. 9:2012 F - Fire safety in restaurants
- Guideline No. 10:2008 F - Smoke alarms in the home
- Guideline No. 11:2015 F - Recommended numbers of fire protection trained staff
- Guideline No. 12:2012 F - Fire safety basics for hot work operatives
- Guideline No. 13:2015 F - Fire protection documentation
- Guideline No. 14:2007 F - Fire protection in information technology facilities
- Guideline No. 15:2012 F - Fire safety in guest harbours and marinas
- Guideline No. 16:2016 F - Fire protection in offices
- Guideline No. 17:2015 F - Fire safety in farm buildings
- Guideline No. 18:2013 F - Fire protection on chemical manufacturing sites
- Guideline No. 19:2009 F - Fire safety engineering concerning evacuation from buildings
- Guideline No. 20:2012 F - Fire safety in camping sites
- Guideline No. 21:2012 F - Fire prevention on construction sites
- Guideline No. 22:2012 F - Wind turbines – Fire protection guideline
- Guideline No. 23:2010 F - Securing the operational readiness of fire control system
- Guideline No. 24:2016 F - Fire safe homes
- Guideline No. 25:2010 F - Emergency plan
- Guideline No. 26:2010 F - Fire protection of temporary buildings on construction sites
- Guideline No. 27:2011 F - Fire safety in apartment buildings
- Guideline No. 28:2012 F - Fire Safety in laboratories
- Guideline No. 29:2013 F - Protection of paintings: Transport, exhibition and storage
- Guideline No. 30:2013 F - Managing fire safety in historical buildings
- Guideline No. 31:2013 F - Protection against self-ignition and explosions in handling and storage of silage and fodder in farms
- Guideline No. 32:2014 F - Treatment and storage of waste and combustible secondary raw materials
- Guideline No. 33:2015 F - Evacuation of people with disabilities
- Guideline No. 34:2015 F - Fire safety measures with emergency power supplies
- Guideline No. 35:2017 F - Fire safety in warehouses
- Guideline No. 36:2017 F - Fire prevention in large tents
- Guideline No. 37:2018 F - Photovoltaic systems: Recommendations on loss prevention



Natural hazards

- Guideline No. 1:2012 N - Protection against flood
- Guideline No. 2:2013 N - Business Resilience – An introduction to protecting your business
- Guideline No. 3:2013 N - Protection of buildings against wind damage
- Guideline No. 4:2013 N - Lightning protection
- Guideline No. 5:2014 N - Managing heavy snow loads on roofs
- Guideline No. 6:2015 N - Forest fires
- Guideline No. 7:2018 N - Demountable / Mobile flood protection systems: Recommendations on planning, selection, providing and using.

Security

- Guideline No. 1:2010 S - Arson document
- Guideline No. 2:2010 S - Protection of empty buildings
- Guideline No. 3:2010 S - Security system for empty buildings
- Guideline No. 4:2010 S - Guidance on key holder selections and duties
- Guideline No. 5:2012 S - Security guidelines for museums and showrooms
- Guideline No. 6:2014 S - Emergency exit doors in non-residential premises
- Guideline No. 7:2016 S - Developing evacuation and salvage plans for works of art and Heritage buildings
- Guideline No. 8:2016 S - Security in schools
- Guideline No. 9:2016 S - Recommendation for the control of metal theft
- Guideline No. 10:2016 S - Protection of business intelligence